





TECHNICAL SHEET

MARTE 50

- 

Posizionatore a tavola rotante, portata 50 kg.
Rotazione con motore a corrente continua.
Schermatura alta frequenza HF.
- 

Turntable type positioner, load 50 kg.
Slewing by DC motor.
High frequency (HF) shielding.
- 

Positionneur à table rotative, portée 50 kg.
Rotation avec moteur à courant continu.
Protection haute fréquence HF.
- 

Drehtisch - Positionervorrichtung, Tragkraft 50 kg.
Rotation mit Gleichstrommotor.
Hochfrequenzabschirmung HF.
- 

Posicionador de mesa giratoria con carga 50 kg.
Rotación por motor de corriente continua.
Protección alta frecuencia HF.
- 

сварочные вращатели грузоподъемностью 50 кг.
Вращение с помощью мотора DC для защита от HE - напряжения.

MARTE 50



VERTICAL LOAD

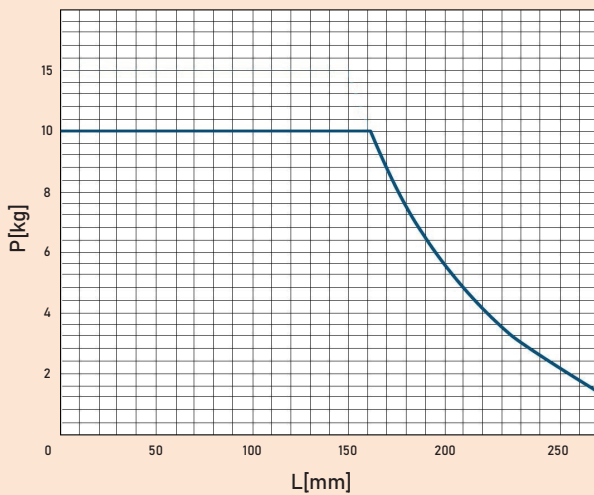

HORIZONTAL LOAD

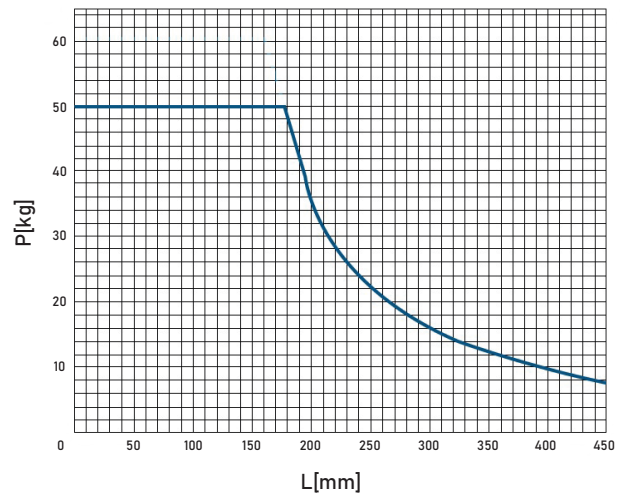

Tipo motore	L mm	W mm	H mm	Fø mm	volt Вольт	rpm	Portata / Load / Portee / нагрузка / Tragkraft / Capacidad		Kg / кг
							Horizontal Kg / горизонт. кг	Vertical Kg / вертикал. кг	
DC	170	170	227	150	24	0,5 - 6	50	10	6

produced by



AUTOMA
2000

R·A·M

OPTIONAL KIT

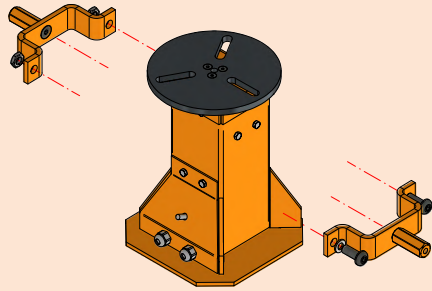

N° OPERAZIONE

1

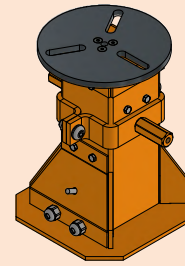

N° OPERAZIONE

2

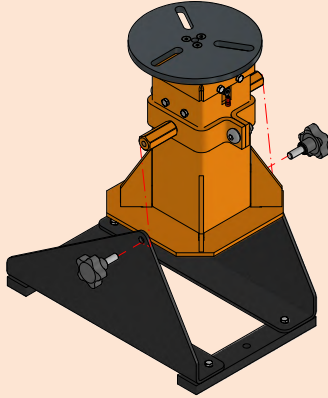

N° OPERAZIONE

3

